

REVISIONS			
REV.	DESCRIPTION	DATE	APPROVED

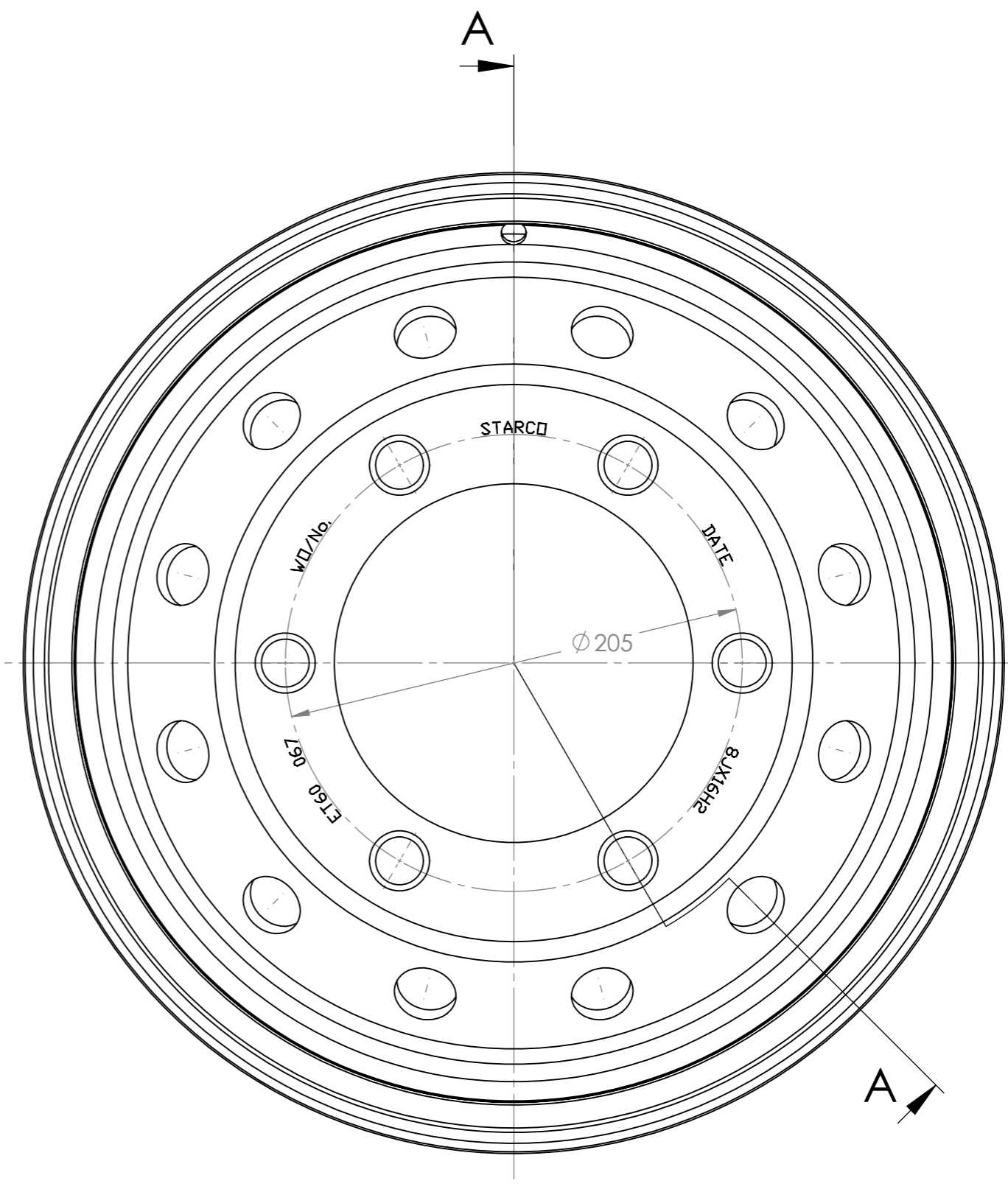
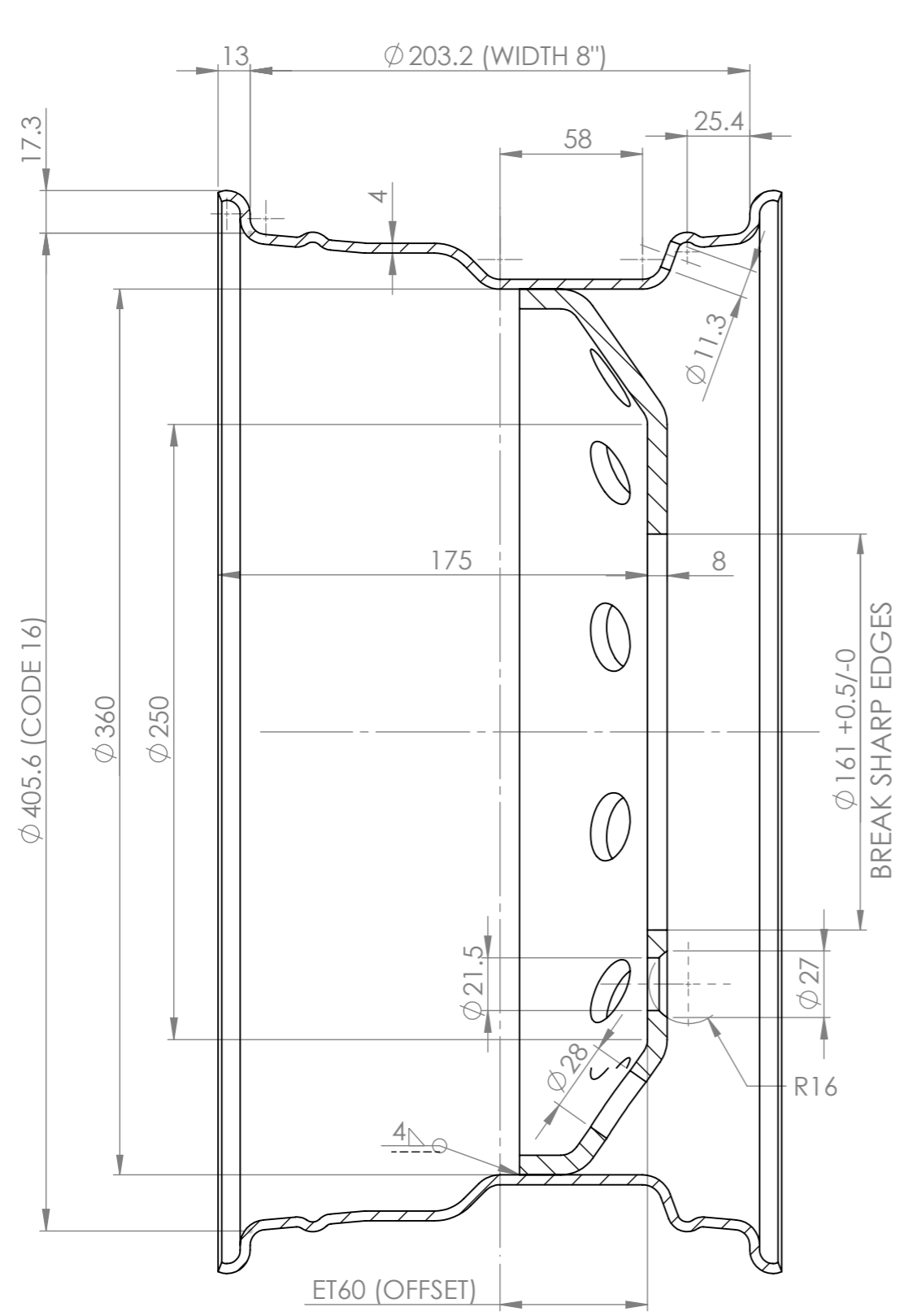

FOR RUN-OUT SEE DRAWING TI001 (HSH)

MAX LOAD 1850kg @ 110km/h DR
 MAX LOAD 2000kg @ 70km/h DR
 MAX TYRE O/D 790mm
 MAX INFLATION PRESSURE 5.7BAR

ALL DIMENSIONS IN mm
 UNLESS OTHERWISE STATED



The drawing is the property of THE STARCO GROUP of companies and may not be used for any purpose other than that for which it is supplied.
 This drawing must not be copied by any means including electronic transmission to any 3rd party.
 For details contact STARCO Engineering.
 Tel: (+44) (0) 1889 571030

TITLE:
 8JX16 H2 WHEEL

6/205/161 ET60 21.5 R16

DWG NO. P160-080-067-STR

DRAWN BY: S B WEBB

DATE 04/11/2016

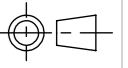

SCALE: NTS

SHEET 1 OF 1

Bill of Materials		
ITEM NO.	PART No.	Material
1	60080160S12	DD11
2	61P1600142	S355

1 2 3 4 5 6 7 8

A B C D E F